

**WORKING  
WITH YOU**  
for  
*Stress Free  
Personalised*  
**PACKAGING**

**WE MAKE COOL THINGS**  
In Queensland

weltrade

**30**  
+ YEARS  
EXPERIENCE

**EST.  
2005**

100% AUSTRALIAN OWNED & OPERATED



**Statement of Confidentiality:** This proposal and supporting materials contain confidential and proprietary business information of Weltrade Packaging. These materials may be printed or photocopied for use in evaluating the proposed project, but are not to be shared with other parties. As per our Terms & Conditions on the website. [www.weltrade.com.au](http://www.weltrade.com.au)

# DIRECTORS STATEMENT

*I have a confession to make...* I am passionate about cosmetic packaging! You might even call me a packaging tragic.

I'm that guy you see in supermarkets and high-end department stores picking up bottles and jars and examining them. When traveling overseas for business and family holidays – I tend to be looking at packaging (in all different shapes and sizes) to pick up on emerging trends and how it could apply to the skin care industry.

I started in Packaging in 1994 with a plastic injection and plastic extrusion blow molding company. This was a great experience to learn the differences in resins and how they react when paired with different formulations.

In 2005 we established Weltrade Packaging to satisfy the need for a complete packaging solution for the personal care space. We now service brands all over the world with expertise that covers the full spectrum from concept to design to on time supply management and follow up service.

I am proud of the team we have brought together that share in my values to make sure that the packaging process is stress free and helps our clients achieve their goals

**FOR**  
*Stress Free*  
*Personalised*  
**PACKAGING**

## **What do you love about packaging?**

I get asked what is it that I love about packaging? The honest answer is when I get to see our clients products succeed by getting on retailer's shelves or winning awards for their category. I understand the time they and us put into each packaging project and feel a part of their journey

## **Biggest Achievement?**

Our greatest packaging achievement is getting to where we are from starting this business in 2005. Even though I already had 11 years background in the manufacture of packaging, to start from zero to build this business to one that works regularly with brands of all sizes from FMCG to start up brands looking to make their mark. The next couple of years are looking really exciting for Weltrade Packaging

## **Where to?**

Moving forward I would like Weltrade Packaging to be synonymous with packaging for personal care and also wellness industries. We work hard in providing free content for various groups of industry professionals on LinkedIn around the world and honored to be the packaging specialist in the bimonthly edition of Science of Beauty. Through research and writing it makes sure our team stay ahead of the curve and continue to provide a solution for your packaging needs..



**Steve Welsh**  
CEO of Weltrade Packaging

January 2024

# INTRODUCTION

With over 20 years experience in supplying and packaging design we can provide a creative custom solution or tweak one of our many proprietary packaging options to get exactly the look and features you need for your packaging. We are a specialist in manufacturing and supplying today's most innovative, high quality plastic packaging to hair, skin, beauty and pharmaceutical, product manufacturers or brands. Our mission statement "is to develop ground breaking, problem solving solutions to meet and exceed our customer's needs".

With manufacturing capabilities at our facility on the Gold Coast as well as numerous options with our offshore partners, we can supply tubes, bottles, jars, pouches, pumps, sprays and more. We have expertise in custom colouring, screen printing, hot foil, labels, shrink sleeves, custom tooling and a dedicated sourcing team. We are always ready to assist and we want to provide you with a stress-free approach to your packaging.



With offices and Onsite Manufacturing facility in Queensland, we pride ourselves on offering a personal service. Our team of experienced professionals means we cover all aspects of the packaging supply chain including -

- Expert advice on what can work and how to carry out product in-package testing.
- In-house specialist packaging designers for a 100% custom design that will make an impact.
- Latest 3D CAD mold design and technology.
- Technical expertise in extrusion blow molding, injection molding, two stage PET packaging production and tube extrusion.
- Full time dedicated quality control staff checking products to specifications.
- Logistics networks to your filling location anywhere in the world.
- These are co-ordinated by our customer care team to ensure you have all the information to make the right decisions for your project and that it arrives on time for filling.
- ISO approved 9001:2015 certification.
- HACCP certified.



# ABOUT THE COMPANY



## Who we are

Weltrade has been established for over 20 years, and service clients all over Australia and internationally. We are known for our service and high quality products, and being able to deliver on time.

*Full time dedicated quality control staff checking products to specifications*

## OUR MISSION

Our Mission statement is to develop ground breaking, problem solving solutions to meet and exceed our customer's needs. Our packaging will not only keep your product safe, it will assist in boosting your sales by making a great first impression.

## What Makes us different?

We strive to be the best at what we do and offer:

- *Australian Owned and Operated*
- *Family Business*
- *Accredited ISO 9001:2015 Quality Management System*
- *Accredited HACCP certification*
- *We push the boundaries to give you a point of difference.*
- *Provide outstanding Customer Service*
- *In house design*
- *Expertise in manufacturing*
- *Onsite Manufacturing facilities*
- *We can provide our customers Sustainably options to promote a greener earth*

## OUR VALUES



# FOOD SAFETY & QUALITY POLICY STATEMENT

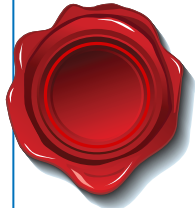

As part of our continuing commitment to quality improvement, control & performance, Weltrade Packaging Pty Ltd places special emphasis on understanding client requirements in order to meet and exceed their expectations. Helping to ensure the products manufactured by their operations are protected from any physical, chemical or microbiological contamination, that could result from packaging. This allows us to meet our legislative requirements under the Food Standards Code, Food Act 2006 and Competition and Consumer Act 2010, environmental and WH & S obligations.

We understand that continual improvement and of the Weltrade Packaging Pty Ltd quality management system is essential to our success and growth within our industry and to assure this have committed to set and review specific and measurable quality objectives and targets on a quarterly basis at management review meetings.

Weltrade Packaging Pty Ltd has a proven track record of providing quality solutions and services to our clients and stakeholders, thus giving us a competitive advantage in the market place. Our history of service provision has led to new and repeat business based on high levels of customer satisfaction.

The consequent objectives of management and personnel of Weltrade Packaging Pty Ltd are to:

- Implement and maintain a quality management system;
- Implement Good Manufacturing Practice (GMP) and maintains a Food Safety Program in accordance with HACCP systems.
- Be responsible as a food packaging manufacturing operation
- Provide objective evidence that the planned quality management system is implemented and maintained in accordance with management policies;
- Seek to understand customer requirements and act promptly and courteously to all customer feedback
- All employees are encouraged to perform their job in a manner which supports this quality and food safety policy.

The Quality Management System outlined in this Manual is designed to satisfy the requirements of AS/NZS ISO 9001: 2015 and has the full support of management and personnel of Weltrade Packaging Pty Ltd, and its successful implementation and maintenance is a commitment by them. Proper adherence to all quality related activities, legislative, standards and active participation in all quality related activities are a requirement of all personnel in the Company. As of August 2024 we are currently working towards our HACCP certification, and hope to have this by the end of December 2024.

Steve Welsh  
CEO of Weltrade  
AUGUST 2024



# OUR CERTIFICATIONS



## CERTIFICATE OF CONFIDENCE

This is to certify that

**Welltrade Packaging**  
20 Harnett Place, Melbourne QLD 4214, Australia

conforms to the requirements of

**ISO 9001:2015**  
Quality management systems

Design, manufacture, and distribution of packaging products.

---

|  |                                      |
|--|--------------------------------------|
| <b>Certificate number:</b> WFP001-000004 | <b>Certified date:</b> 28 March 2023 |
| <b>Original date:</b> 17 January 2010    | <b>Expiry date:</b> 17 January 2024  |

*Terry Doherty*  
**Terry Doherty**  
Business Development  
Assurance Manager  
Equal Assurance









Equal Assurance Pty Ltd is a member of The Equal Assurance Trust  
277 Bridge Street, Brisbane QLD 4000, Australia  
Equal Assurance is an ISO 9001:2015 certified organisation and Equal Assurance  
Certification is an ISO 9001:2015 certified organisation. Equal Assurance  
Business Development Manager is a member of the International Institute of  
Business Development Managers (IIBDM) and is a member of the  
International Institute of Business Development Managers (IIBDM).  
Equal Assurance Pty Ltd is a member of The Equal Assurance Trust  
277 Bridge Street, Brisbane QLD 4000, Australia

ISO - Due 2024



minimise the hazard - reduce the risk



This is to certify that

**Welltrade Packaging Pty Ltd**  
20 Harnett Place, Melbourne QLD 4214

has been assessed and found to meet the requirements of HACCP - Codex Alimentarius Annex to CAC/RCP 1-1969 (Rev. 2020) and has achieved

**Full Certification**  
Scope: Manufacture and dispatch of food grade primary packaging

in accordance with the requirements of HACCP Australia - Food Safety Certification Program



**28 March 2024**  
Issue Date

The scope of this certificate is limited to the manufacture and dispatch of products as described in this Certificate. The certificate is not valid unless it is accompanied by a copy of the HACCP Australia Pty Ltd - Certification Program.

Certificate Number: **FSP-1579-WP-02**



minimise the hazard - reduce the risk

|                             |                |
|-----------------------------|----------------|
| Certification Statement     | FSP-1579-WP-02 |
| Welltrade Packaging Pty Ltd |                |

HACCP Australia Pty Ltd certifies Welltrade Packaging Pty Ltd in its application of a HACCP based Food Safety Programme in accordance with Food Standards Australia guidelines and the relevant Codex Alimentarius Annex.

|                         |               |
|-------------------------|---------------|
| Licence Commencement    | 29 March 2023 |
| Certificate Expiry Date | 28 March 2024 |

Whilst all reasonable care is taken by HACCP Australia Pty Ltd in its assessment of the food safety programs referred to herein, HACCP Australia does not guarantee that every food safety risk has been identified or addressed and no guarantee is offered or implied in the issue of this statement.

**Licence Agreement**

Welltrade Packaging Pty Ltd is licensed to use the HACCP Australia certification logo in accordance with the Certification Trade Mark Rules and Conditions (July 2011 v2.4) of HACCP Australia Pty Ltd for a period of 12 months from the above date. Welltrade Packaging Pty Ltd is in receipt of the HACCP Australia Pty Ltd - Certification Trade Mark Rules and Conditions - July 2011 v2.4 and has agreed to abide by the conditions therein.

|                          |                           |
|--------------------------|---------------------------|
| HACCP Australia Pty Ltd: | Issue Date:<br>30/03/2023 |
|--------------------------|---------------------------|

Unit 9 Highview Building, 11 Hodge Street, North Sydney, NSW 2060 Australia  
T: 02 9556 9211 www.haccp.com.au ABN 71 078 738 876  
RPO: 000001, 000002, 000003, 000004, 000005, 000006, 000007, 000008, 000009, 000010, 000011, 000012, 000013, 000014, 000015, 000016, 000017, 000018, 000019, 000020, 000021, 000022, 000023, 000024, 000025, 000026, 000027, 000028, 000029, 000030, 000031, 000032, 000033, 000034, 000035, 000036, 000037, 000038, 000039, 000040, 000041, 000042, 000043, 000044, 000045, 000046, 000047, 000048, 000049, 000050, 000051, 000052, 000053, 000054, 000055, 000056, 000057, 000058, 000059, 000060, 000061, 000062, 000063, 000064, 000065, 000066, 000067, 000068, 000069, 000070, 000071, 000072, 000073, 000074, 000075, 000076, 000077, 000078, 000079, 000080, 000081, 000082, 000083, 000084, 000085, 000086, 000087, 000088, 000089, 000090, 000091, 000092, 000093, 000094, 000095, 000096, 000097, 000098, 000099, 000100

HACCP- Due 2024

# WHAT WE ARE KNOWN FOR



## EXPERIENCE

With our CEO Steve and his 30+ years of experience which he has passed onto all staff. The team at Weltrade Packaging have the experience and knowledge to inform our customers with correct information regarding their packaging.



## A PERSONAL SERVICE

We will be there for any questions regarding your packaging. We believe in providing exceptional customer service and are contactable via email, phone, or in person, 5 days a week.



## QUALITY PRODUCTS

Weltrade Packaging is an ISO compliant company with our factories also being ISO approved and assessed to meet Australian standards. This means you will not need to worry about your packaging being any different from what you ordered.



## EDUCATION

The Packaging industry can be quite daunting as the terminology and information you will need to know before picking your packaging can be confusing. We will educate you and help you along the way so that you can be rest assured you've made the right decision.



## CUSTOM MOULDS

Modifying a stock item is a fast, simple way to get a unique look without the cost of tooling up a complete package.



## PACKAGING DESIGN

Don't have a designer or your designer isn't pre-press trained. We are happy to offer our in-house packaging designer for your packaging artwork needs.



NOWAY PROTEIN

Hydrolyzed Collagen Peptides

NOWAY PROTEIN

Hydrolyzed Collagen Peptides

L'abode  
Packaging

dermeze

MOISTURISING  
LOTION

# OUR SUSTAINABILITY OPTIONS

**As we are Qld made and owned. Weltrade is Australia's Premier Plastic Bottle Manufacturer, leading the way in sustainable packaging solutions!**

## **Recyclable & Recycled Plastics:**

Our commitment to the environment shines through in every bottle we produce. Our packaging is crafted from recyclable materials, and we proudly incorporate recycled plastics to reduce waste and promote circularity.

## **Biodegradable & Bioplastic Options:**

We offer a range of biodegradable bottles that naturally break down, minimizing environmental impact, leaving zero micro plastics. Additionally, our cutting-edge bioplastic tube options provide a sustainable alternative to traditional plastics, reducing reliance on fossil fuels both options are recyclable.

## **Ocean-Waste Transformation:**

We're dedicated to cleaning our oceans, one bottle at a time. Our innovative technology transforms ocean waste into durable, high-quality tubes. By choosing our products, you're contributing to the restoration of our precious marine ecosystems.

## **Good-Grade Quality:**

We maintain the highest quality standards, ensuring that our bottles not only meet but exceed industry expectations. Your products deserve nothing less than the best.

Join us in the journey towards a greener, cleaner future. Choose our plastic bottles, and let's make a positive impact on the planet together. Together, we can reduce waste, conserve resources, and create a brighter, sustainable tomorrow. Contact us today to discuss your packaging needs and be part of the sustainable solution!

1. **Sustainable Packaging Leader:** We're Australia's premier plastic bottle manufacturer, renowned for our commitment to sustainable packaging solutions.
2. **Eco-Friendly Options:** Choose from recyclable, recycled, biodegradable, and bioplastic bottles, all designed to reduce environmental impact.
3. **Ocean-Waste Transformation:** Be part of the solution to ocean pollution - our innovative technology transforms ocean waste into high-quality bottles, contributing to marine ecosystem restoration.

**WE MAKE COOL THINGS**  
In Queensland

**At Weltrade Packaging we are making it our mission to provide packaging that will help improve our global footprint and sustainability. Where possible, our packaging is 100% recyclable, however with further steps we have improved our environmental stance even more.**

#### PCR & rPET Plastic

PCR (Post Consumer Resin) and rPET plastics can be made with up to 100% recycled plastic, this reduces the volume of wastes piling up in landfills. They are made from plastics marked for recycling, there are gathered up, washed, dried, made into pellets, crystallized, and later remade into another form. This process is like a never-ending loop of sustainability. Our PCR & rPET plastic is available in any of our tubes, HDPE bottles, PET bottles and Jars.

#### Bioplastic

Sugarcane based bioplastic are a great sustainable, environmentally friendly packaging solution. It reduces the reliance on fossil fuels, such as oil for the production of plastic packaging, by using renewable resources. At Weltrade Packaging we can supply any of our single layer or five layer PE tubes from bioplastic derived from sugarcane. It is durable, protective & 100% recyclable and helps relay an effective marketing message on "Greener" packaging.

#### Biodegradable Packaging

We can now do Biodegradable Packaging across our packaging range. Our Biodegradable packaging is available in PET, HDPE, LDPE and PP, which we can implement into our bottles, jars, tubes and more! Our biodegradable packaging will not discolour the base material, it does not taint or alter the chemical stability and functionality of the packaging. Our biodegradable packaging is FDA approved and completely food safe.



# OUR ONSITE MANUFACTURING FACILITY



At the beginning of 2019 we opened up our onsite manufacturing facility to focus on Australian Made packaging. We moved into a new facility in Molendinar on the Gold Coast which is where our office, showroom and machinery is located. This move allowed us to supply packaging to a range of new industries, which now include Cosmetics, Skincare, Haircare, Supplement and Pharmaceuticals.

In November 2022 we moved to a new location over three times the size of our previous one, which will enable us to produce more high-quality sustainable packaging on-site while creating more job opportunities for locals. With our recent move, we were able to purchase additional machinery and expand our facility with help from a grant from the Queensland State Government. Among the new machinery is an automated two-stage PET bagging and blow moulding machine, which will help us meet the growing demand for sustainable plastic packaging solutions.

With sustainability being a major focus of ours we installed large 20kw solar panels to lower our carbon footprint. These solar panels supply sufficient energy to help run our office and factory's machinery power demands. We also installed LED lighting throughout our office due to their high energy efficiencies. We are constantly looking for new ways to make our workplace more environmentally friendly.

We currently have 3 separate PET machines installed at our factory, with both automatic and semi-automatic

capabilities. The plastic packaging we make onsite is known as 2 stage PET blow moulding. The process involves starting with the importing of the PET raw material (pre-forms), then we heat, blow and stretch them into the desired shape and deliver to the manufacturer or brand.

Our main PET packaging we manufacture onsite includes, wide-mouth jars, small jars, tablet bottles, juice/probiotic bottles and now even hand sanitiser bottles. Some of our clients have created their own unique shapes, which they have setup new moulds and are now selling millions of units to retail stores like Coles and Woolworths.

Our Unique Value Proposition has always been our ability to provide clients with a stress-free end-to-end personalized-packaging solutions for clients within Australia, by coordinating the design, production and import of packaging solutions. Now with our onsite manufacturing we have seen major growth and we are well-placed to continue growing strongly into the coming years. We have now even started exporting product to Asia, which seemed inconceivable just a few short years ago.





## OUR QLD MANUFACTURING OPERATIONS

At Weltrade Packaging Manufacturing operations we run 2 stage PET production machines. This means our set up cost and flexibility is much lower than other plants running single stage PET machines. This also does not hinder our push to more sustainable packaging with recycled materials and biodegradable options.

### DY5000

Our range of DY5000 machines have the capability to manufacture **89mm to 120mm necks** of the wide mouth jars with a full capacity of 450ml to 6.5L.



**WE MAKE COOL THINGS**  
In Queensland



Labour and other resources in our manufacturing operations are budgeted and planned weekly production meetings between sales and production teams.

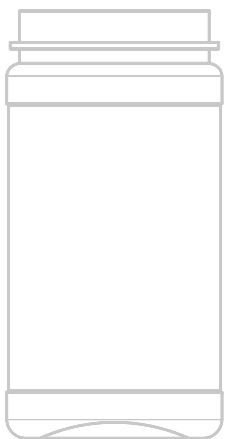



### DY2000

Our range of DY2000 machines can produce up to 1/2 liter bottles with an output of 2000 Bottles per hours.

We can produce bottles and jars

- 28mm necks
- 38mm necks
- 63mm necks

In Standard PET or sustainable plastics. We have the option to automatically leak detect and bag directly off the line onto pallets.

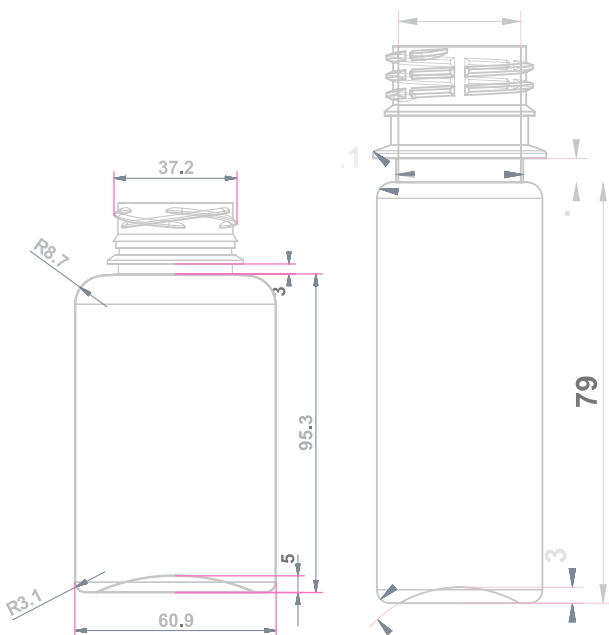

er  
ur  
eration  
anned at  
meetings  
nd  
ms.

## Semi

Semi Automatic is for our smaller order needs but can make up to a 5.3L jar. This allows products to be made for brands that don't have the volume for full automatic production however with a set up cost starting from \$3000 for a custom shape it is a great entry to the market machine.



## Warehouse

Our Gold Coast warehouse is 4210sq meters with 465 pallet bays. Weltrade Designed the racking before we moved in and is in the process of implementing our warehouse management system - which will make it all digital

# IN THE NEWS



Australian Government  
Department of Industry, Science,  
Energy and Resources

**Business**  
Entrepreneurs' Programme

Success stories

## Reshoring repackaged

Import replacement becomes  
export opportunity



Weltrade Packaging Solutions has provided custom-designed packaging and dispensing systems for therapeutic, nutraceutical and pharmaceutical companies since 2005.

### Not broken, so why fix it?

Weltrade's Unique Value Proposition had always been their ability to provide clients with a stress-free end-to-end personalized-packaging solution for clients within Australia, by coordinating the design, production and import of packaging solutions from their network of contacts in Asia.

Business was growing really well, but Weltrade's CEO Steve Welsh courageously decided to allow a Growth Facilitator from the Entrepreneurs' Programme to come in and "kick the tyres" on his business.

A cost-free review was completed and opportunities to improve were considered. Marketing messaging, ISO-accreditation and software investment were each identified as areas that the business might benefit from focusing on.

### Customer interviews uncover new opportunity

With the help of an external consultant, a number of Weltrade's key customers were also interviewed to understand what was working well, what was not, and what these customers hoped Weltrade could do for them in the future. The overwhelming response was a desire for locally-based niche manufacturing options to be made available.

### Fortune favours the brave

Armed with this new intel, Weltrade explored the feasibility of bringing some manufacturing options home to South-East Queensland as an import

replacement. After lengthy consideration, a new production facility was purchased and investments in manufacturing equipment, additional qualified staff, and new systems and processes, were also completed.

"I think the biggest advantage is that it reinforced the view that we need to be less reliant on myself and set up systems and get the right people around so that we can all grow with the business rather than just the directors." CEO Steve Welsh

### Imported cost becomes export revenue

The onshoring project has been a major success and Weltrade are well-placed to continue growing strongly into the coming years. They have even started exporting product to Asia, which seemed inconceivable just a few short years ago.

business.gov.au | call 13 28 46

Delivered in partnership with

**Deloitte.**

# HOW WE WORK

At Weltrade Packaging we divide our operation processes into three main phases.

## PHASE 1 – PRE SALE

This includes our marketing activities, sourcing the best way to meet your packaging brief, making sure we can offer you a competitive quote, arranging samples and following up with you until you are ready to order.

In this stage you will deal with the admin and sales teams.

**Lead Time from 3 days +**

**PRE SALE PHASE 1001**

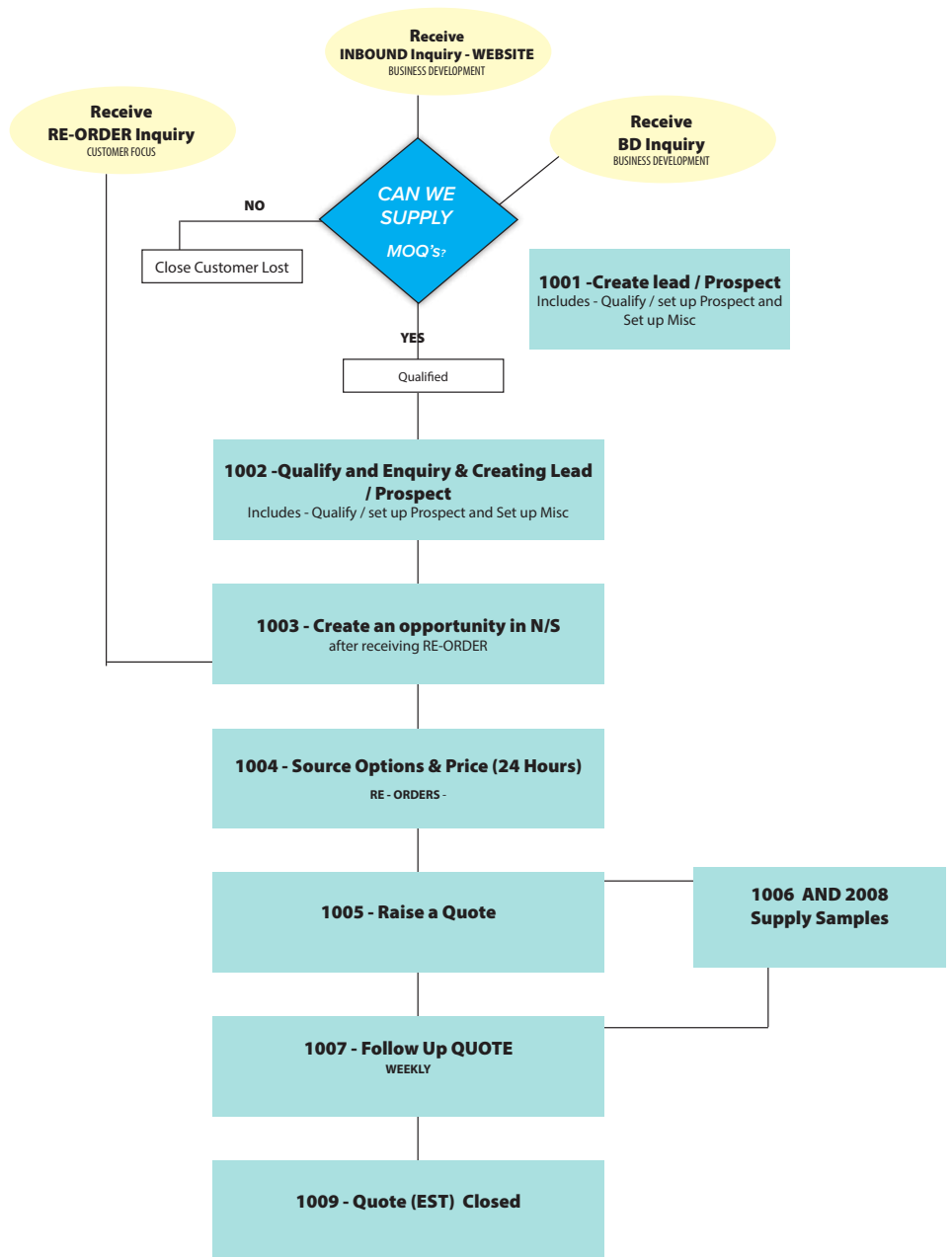

## PHASE 2 – PRODUCTION

Once you place your order, this project will be assigned to one of our customer care team members to project manage the job all the way until you receive it. This includes coordinating any artwork to make sure it meets our printer specifications and dealing with supply chain partners both internal and external to bring all elements together and get all the goods ready to send to you.

**Lead Time from 4 – 16 weeks**

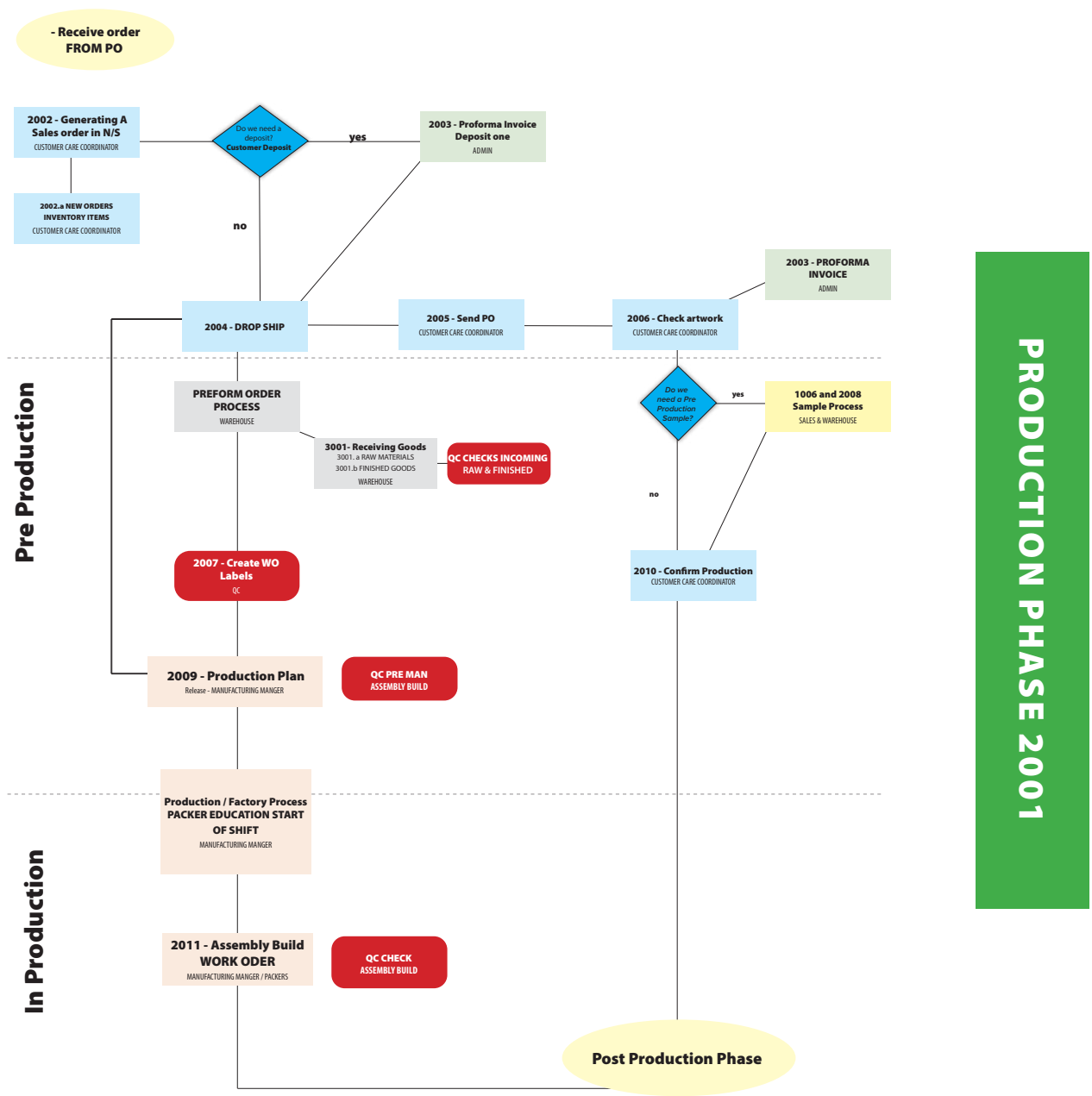

## PHASE 3 – POST PRODUCTION

This is our wrapping up phase, where we do final checks, pack your order and freight to your location, close off the financial side and check in with you to make sure everything is received. Your customer care team member be the main point of contact again.

**Lead Time from 1 to 3 weeks**

All phases are as important as each other.

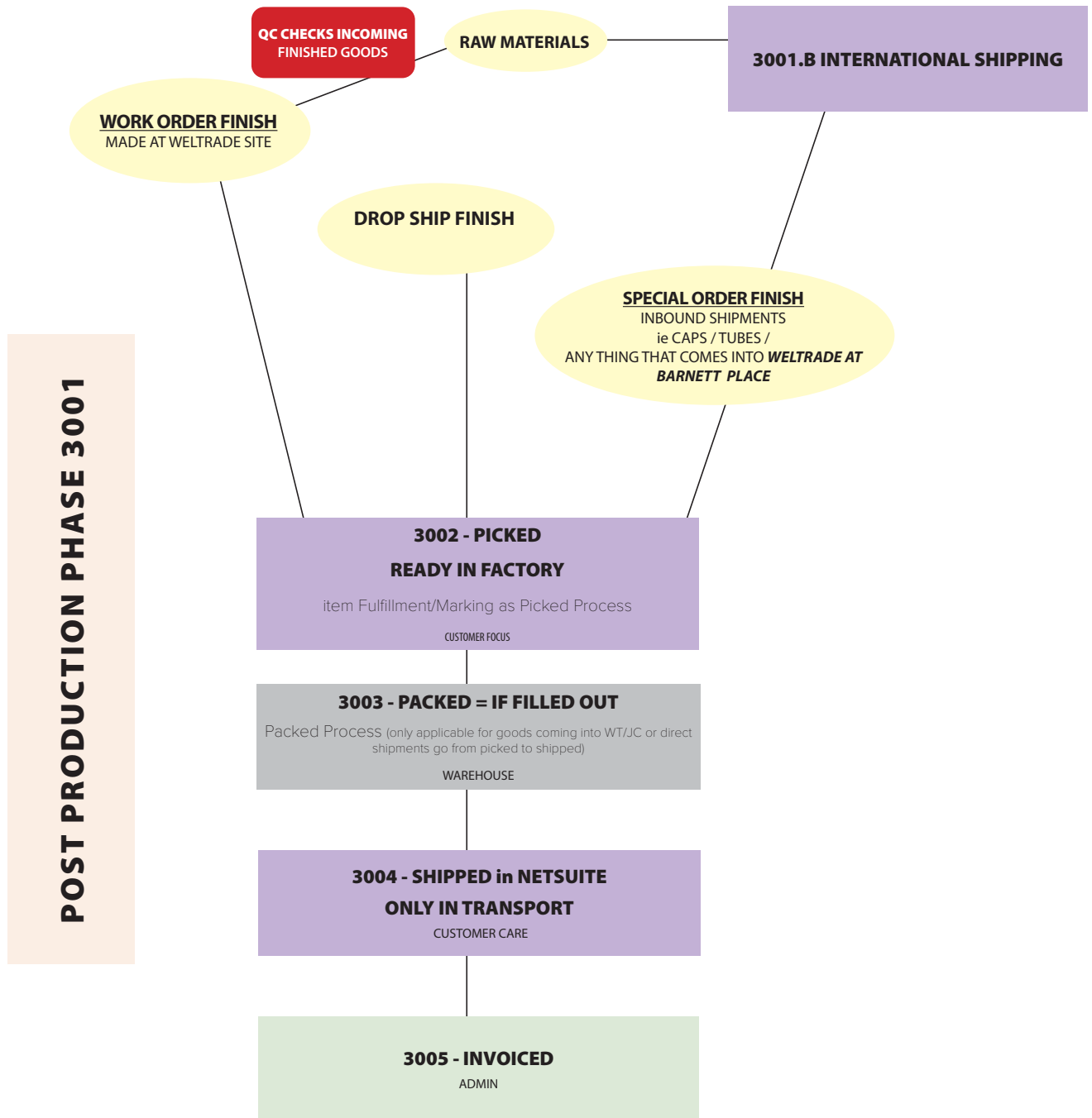

## OUR RIGOROUS QUALITY ASSURANCE PROCESS

### Empowering a Culture of Quality”

**Quality is of paramount importance to us at Weltrade Packaging. We uphold our commitment to quality through a comprehensive approach that integrates traceability within the principles of Hazard Analysis and Critical Control Points (HACCP).**

Our experienced staff conducts regular Quality Control (QC) checks to ensure that we consistently adhere to the standards established by our ISO-approved Quality Management System. These checks are not limited to our in-house manufacturing processes; they extend throughout the production cycle, encompassing both post-manufacture assessments and random spot checks before dispatch.

When it comes to our imports, our dedicated team in China conducts rigorous inspections to verify compliance with agreed-upon specifications. This proactive approach ensures that only goods meeting our stringent criteria are shipped, guaranteeing no unwelcome surprises upon arrival at your port. Furthermore, our QC team performs additional checks upon the release of packaging from quarantine, reinforcing your confidence in receiving precisely what you expect.

Moreover, we take pride in maintaining 100% traceability on all incoming raw materials. This means that we can account for the source and quality of every component used in our manufacturing process, further enhancing our commitment to quality and ensuring that our products consistently meet the highest standards.

At Weltrade Packaging, we prioritize a culture of quality and Good Manufacturing Practices (GMP) across our entire workforce. Our staff members are continually trained, coached, and encouraged to understand the significance of quality in everything we do.

**WE MAKE COOL THINGS**  
In Queensland

## JUST SOME OF OUR CLIENTS

Infor about why we like working with our clients - about building relationships, solving there problems, we check in frequently with our clients we ask for feedback and we exceed our clients expectations and deliver on that. We have a strong understanding of our capabilities and timelines, and being honest.

ALPHA H

ATP  
SCIENCE

aspen  
AUSTRALIA

donutking.

DE LORENZO

fisiocrem<sup>™</sup>  
SOLUGEL

KORA<sup>™</sup>  
Organics by Miranda Kerr

Mater  
Exceptional People. Exceptional Care.

NATIO  
AROMATHERAPY

paw<sup>®</sup>  
PureAnimalWellbeing  
by BLACKMORES

pHisohex<sup>®</sup>  
FACE WASH

Schwarzkopf

esmi  
SKIN MINERALS

henry  
blooms

Dermeze

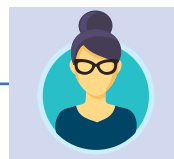

*“The Team is always so helpful, especially Josh!  
Thank you so much for everything you do for us!”*

Feed back from client survey January 2024

## HOW WE CAN TRANSFORM A PACKAGE

Personalisation has been dubbed as the ultimate form of uniqueness. A brand that is unique and creates a sense of intimacy with the customers will succeed. The more unique the packaging is, the more it will stand out from its competitors. At Weltrade Packaging we can transform your packaging to create a point of difference. We can do this by your artwork and by creating custom moulds.

Packaging Artwork can be described as the process of mixing up elements of design, final technical data, regulatory and marketing information into a final graphic file.

A great combination is combining your unique artwork with a custom shape. Weltrade Packaging offers a service of Custom Moulds. This is created by extrusion blow moulding, injection moulding or 2 stage PET moulds. You can also receive a 3D version of your custom mould in only a matter of days.



## OUR RANGE



### JARS

Our extensive range of jars are made from PET, PETG, PP and acrylic and come in many different shapes and sizes to suit your application. We have Wide-Mouth jars options which we manufacture onsite for the food industry plus many other smaller diameter jars available to suit your needs. Our jar range can be custom coloured and the majority can also be silk screen printed.

Our extensive range of jars are made from PET, PETG, PP and acrylic and come in many different shapes and sizes to suit your application.

We have Wide Mouth jars options which we manufacture onsite for the food industry plus many other diameter jars available to suit your needs. Our jar range can be custom coloured and the majority can also be silk screen printed.

## WE MAKE COOL THINGS In Queensland

### PHARMACEUTICAL RANGE

The Pharmaceutical Industry is constantly evolving, so at Weltrade Packaging we make sure to continually provide high manufacturing standards through initial stages of production, right through to delivery. We offer tablet bottles that are made from PET plastic which are BPA free and food grade approved



### BOTTLES

Whether you are after HDPE (High Density Polyethylene), which has a recycle code 2, has a good oxygen barrier, is squeezable & matte in finish OR PET bottles (Polyethylene Terephthalate) which are great for cosmetic and skin care products, with high clarity, good chemical and essential oil resistance, and a recycle code of 1. We are sure to cater most shape options with our stock range of bottles that we can easily colour in your desired tone. Our stock shape range continues to grow by the month.

## TUBES

If it is a tube you are after from 3ml to 400ml, then we have a solution for you. We supply hundreds of thousands of tubes per year to leading cosmetic brands in various formats such as five layer EVOH barrier tubes, single layer, plastic barrier laminate and aluminium tubes. All are made to order, printed or labelled, ready to fill and sell. You can dispense through nozzles and pumps with the option on larger sizes for foil induction seals and flip top caps in matte or gloss finishes, based on your needs.



## DISPENSERS & CLOSURES

We offer a large range of dispensers and closures for all different types of packaging and supply anything from pumps, sprays, caps in a range of different sizes. Specifically, we offer lotion, treatment, foaming pumps, fine mist, trigger sprays, disc top, flip top and screw caps, plus much more.

## AIRLESS SYSTEMS

We offer stock and made to order solutions to suit your needs. Whether it be a recyclable Polypropylene or PETG option, or upscale your brand image with one of our many acrylic shapes. Our external spring dispensing mechanism ensures smooth delivery of your serums to enhance the overall user experience.



## BOX PACKAGING

It is just as important to have high quality box packaging as it is for your product packaging. We offer a range of box packaging, from product boxes, gift boxes, travel boxes, display boxes and more. Boxes are the perfect way to accompany your product to help add an even more premium value to your final goods.

# WHAT TO EXPECT FROM YOUR PACKAGING DESIGNER AT WELTRADE

A company that sells products to customers has many things to worry about, but perhaps the biggest worry (other than having a working product) is marketing. More specifically, a firm must be concerned with how all of the packages are designed. It might not seem like a big deal, but packaging design tends to be a pretty significant part of what makes a business popular. After all, it's the first thing that the customer sees before he/she opens it. It's your chance to make a great first impression before customers even get to look at your product design.

Not everyone has expertise in this area. Thus, it's helpful to seek out the guidance of a packaging designer. This type of designer specializes in making your product stand out in retail, and makes sure that your packaging design and product design complement each other.

## *First Impressions*

The biggest thing that a packaging designer is responsible for is creating a good first impression. Since the packaging is the first thing that customers see, they'll already start to judge your product before they even use it. This means that your packaging design needs not only to accurately reflect what your product does, but also to make sure that it pops out enough that it looks interesting on the shelf. A packaging designer should be able to help you in this area, and help in coming up with ideas. All in all, though, this is the part of packaging design that shouldn't be neglected.

## *Varied Design Skills*

It is often the case that a packaging designer isn't tied to any one company. Instead, he or she might work using contracts. In any case, given that a designer has to cater to the needs of many different companies, it's reasonable to expect him or her to have a wide variety of design skills, whether you're placing something in a can, in a box,

in plastic or wherever. Any designs that are created have to both fit your requirements as well as work nicely in many different forms.

## *A Good Track Record*

The best packaging designers should already have an established reputation, and ideally it should be positive. Anyone can claim to be a packaging designer, but not everyone can claim to have

nail your designs and allow your business to reach new heights.

## *Inventiveness*

Perhaps the most important quality that you should expect from a packaging designer is the use of inventive and innovative techniques and ideas. Yes, it's probably enough to paste your logos, designs and branding all over a box, but what if you require a different kind of

box altogether? Will all of the logos and branding work with that? Does your product design work with it?

Packaging designers that are truly innovative should have no problem impressing you. Do note that while innovation is a good thing, you don't

need to be overly ambitious with your design. If it turns out that a simple box works just fine, then that's the end of that. But if your packaging designer has a better idea, then that's a huge plus.

## *Experience*

Not only in terms of working with many brands in various industries and concentrating on their packaging meaning we stay on trend. But also our experience as what special effects through colour, texture, print, can be

---

Packaging Artwork is the process of combining  
**design elements,  
 final technical data,  
 marketing and regulatory**  
 information into one final graphic!

---

years of practical experience with actual companies. Obviously it's a huge plus if a designer has experience in designing packaging for well-known corporations. The best way to determine a designer's qualifications is to ask for references. If a designer declines to provide you any info, this could be a potential red flag. After all, anyone who has actual experience shouldn't be embarrassed about sharing it, especially if it makes him or her look better. The more experience a designer has, the more likely it is that he or she will

achieved on what medium.

***We enjoy working with our clients as most of our clients have been with us for a long time we have watch many brands go from start up to becoming really successful. Our approach to our clients is "Your success is our success!"***

At Weltrade, branding & identity and packaging design are our expertise. We bring to the table many years of combined experience and are committed to launching your business to new heights by establishing solid and recognizable branding for your company. We will help you every step of the way.

#### ***FIRST IMPRESSIONS COUNT***

The main idea behind all of this design is to establish a solid first impression. Design plays a huge role in this, and it is part of my duty as a qualified designer to make sure that this first impression is both positive and long-lasting. You might be able to change your corporate identity later on, but you can never change the first impression that you make. It's my job, , to make everything as unique as possible so that you can maximize the impact of your first impression.

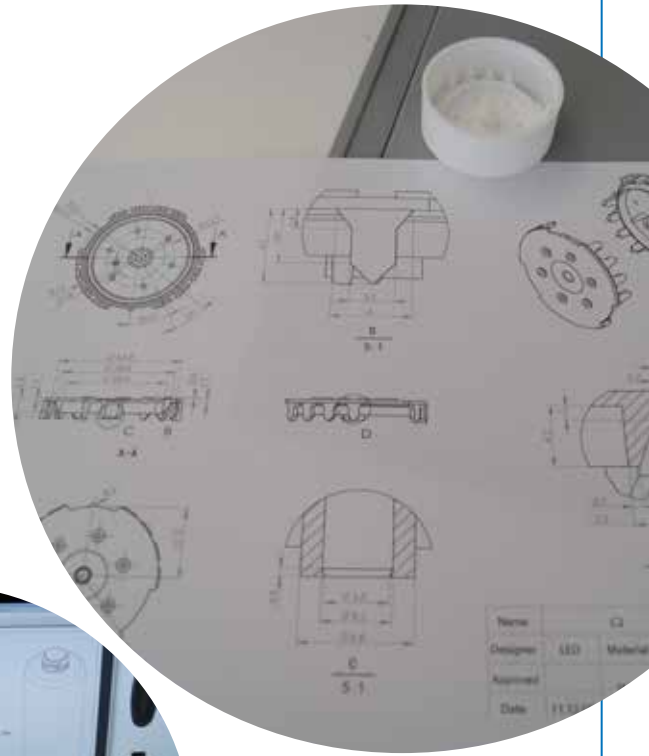



*“Great Supplier. Weltrade are an extension of our business as they help find solutions to all packaging issues. Reliable, efficient and highly recommended”*

Romeo Kekic - Customer 2024



*“Weltrade has been very responsive and helpful to assist us achieve our delivery goals in recent orders. We appreciate the help and kindness and would definitely recommend their service to anyone”*

Susie Liu - Customer 2024



*“The team at Weltrade are consummate professionals. Their head office and manufacturing areas are spotless with tight systems keeping everything humming in pure harmony. Such a pleasure to work with them”*

Dave Turner - Supplier to Weltrade 2022/2024

**CALL US WE WELCOME A  
CONVERSATION**

